 INSTALLATION INSTRUCTIONS	Accessory	Application	Publications No.
	SECURITY SYSTEM	2000 PRELUDE	All 21018
			Issue Date SEP 1999

PARTS LIST

Security System:
P/N 08E51-S84-100

2 Remote controls

Control unit

LED

Push nut

2-Pin connector

Disarm switch

Fuse label

3-Pin connector

3 Nuts, 12 mm

Washer

Owner's Manual

Screw with washer,
4 x 30 mm

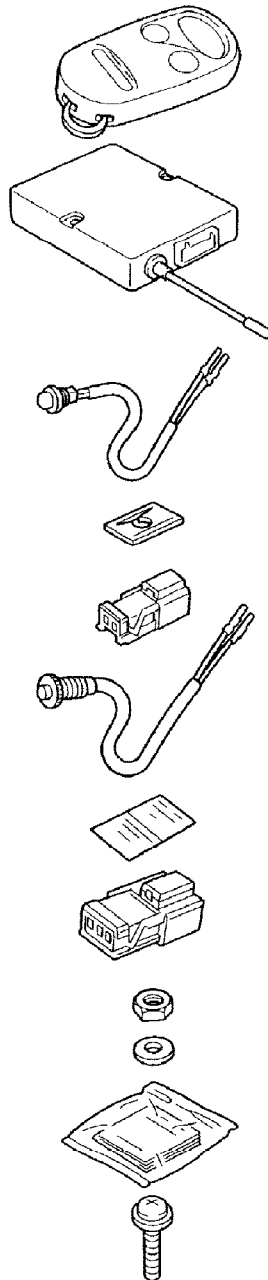

Attachment Kit:
P/N 08E55-S30-101

Security system
wire harness

2 Cushion tapes

Control unit bracket

Fuse label

2 Collars

2 Nuts

10 Wire ties

Self-tapping screw

4-Pin relay

Seal

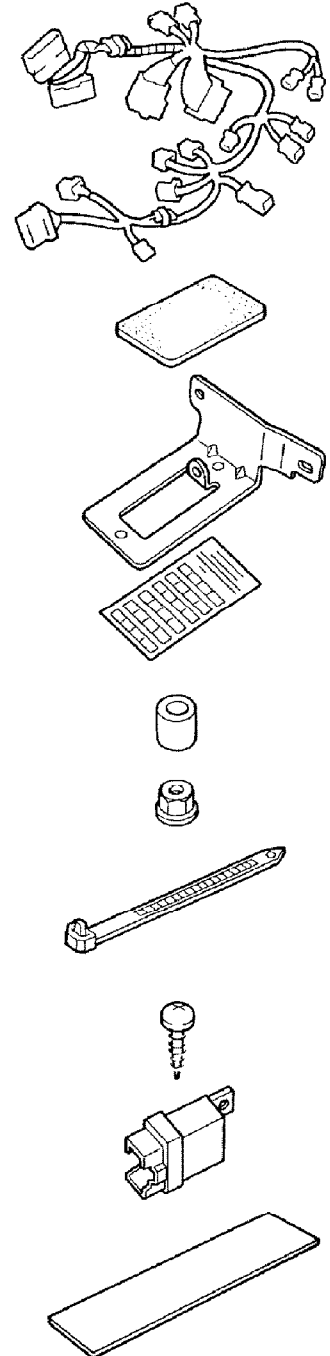

TOOLS AND SUPPLIES REQUIRED

#2 Phillips screwdriver
Eye protection (face shield safety goggles, etc.)
Drill
5.5 mm, 10 mm, and 12 mm Drill bits
Tape measure
File
Felt-tip pen
Pliers
17 mm Open-end wrench
10 mm Socket wrench

Illustration of the Security System Installed on the Vehicle

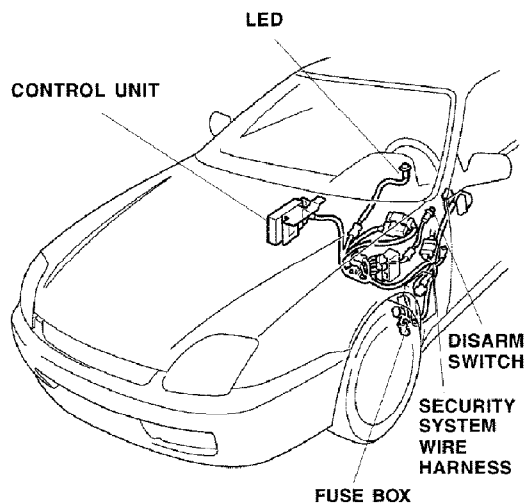

Adjusting The Control Unit

- Use a small flat-tip screwdriver to change the mode switch and the horn/siren switch and to adjust sensitivity.

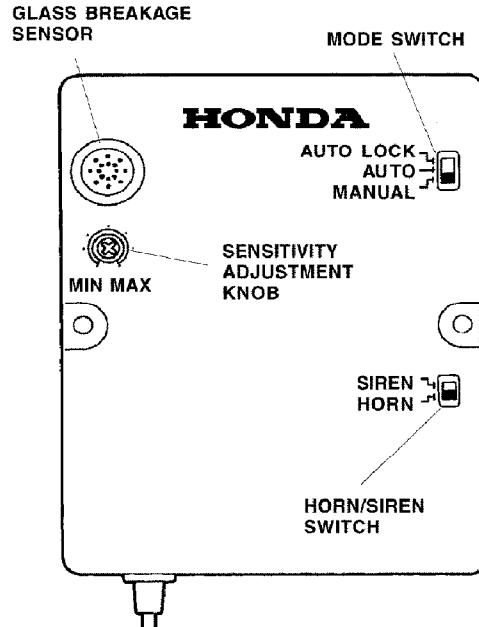

Mode Switch:

- Set the mode switch according to the customer's choice.
- Refer to the Owner's Manual for the explanation of each mode.

Horn/Siren Switch:

- Set the switch to "HORN" in normal use. If an optional siren is installed, set the switch to "SIREN."

Glass Breakage Sensor:

- Do not attach anything like scotch tape over these holes; this is microphone pick-up.

Sensitivity:

- Adjust the sensitivity only if the customer requests it; the sensitivity adjustment of the glass break sensor is factory set.
- Be careful when you adjust the sensitivity, because if you raise the sensitivity too much, the security system can give a false alarm, and if the sensitivity is too low, the security system may not work even if glass is broken.

INSTALLATION

Customer Information: The information in this installation instruction is intended for use only by skilled technicians who have the proper tools, equipment, and training to correctly and safely add equipment to your vehicle. These procedures should not be attempted by "do-it-yourselfers."

1. Make sure you have the anti-theft code, for the radio, then write down the frequencies for the radio's preset buttons.
2. Disconnect the negative cable from the battery.
3. Remove the dashboard lower cover (one self-tapping screw, three retaining clips).

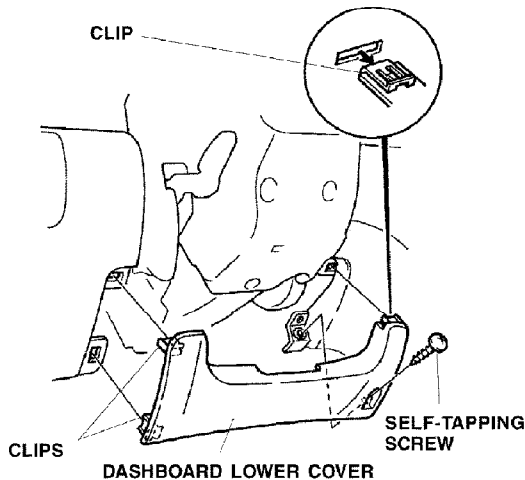

4. Remove the upper steering column cover (three screws, two clips).

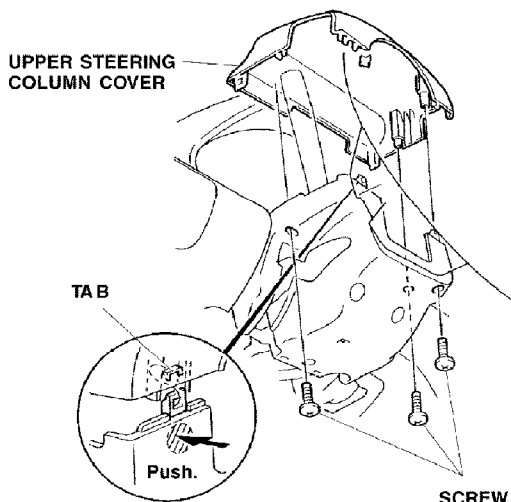

5. Remove the driver's door sill molding, and remove part of the opening seal.

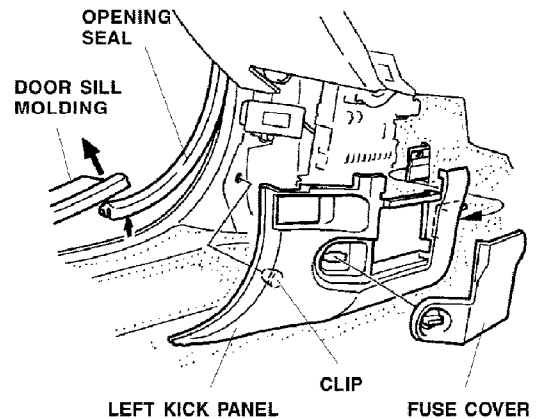

6. Remove the fuse cover.
7. Remove the left kick panel (one clip, and pull).
8. Using a utility knife, cut off the rib from the back of the lower cover. Measure and mark the lower cover as shown, and lightly center-punch the mark.

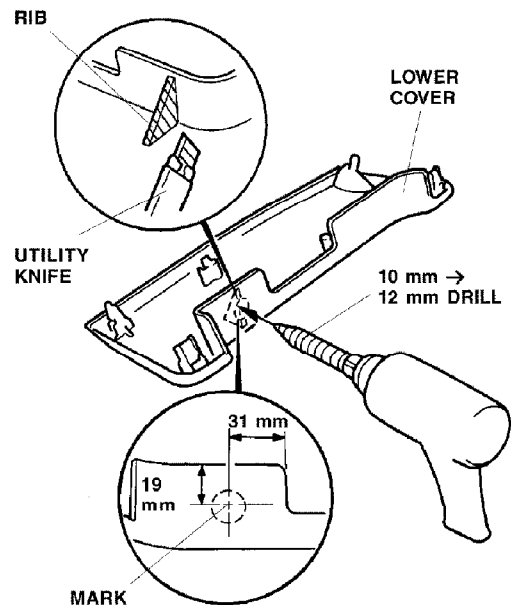

9. While wearing eye protection, drill a 12 mm hole through the center-punched mark.
 - First drill a pilot hole with a 10 mm drill bit, then finish with a 12 mm drill bit.
 - Remove all burrs.

10. Route the terminal ends of the disarm switch through the hole you just drilled, and secure the switch with the washer and the 12 mm nut.

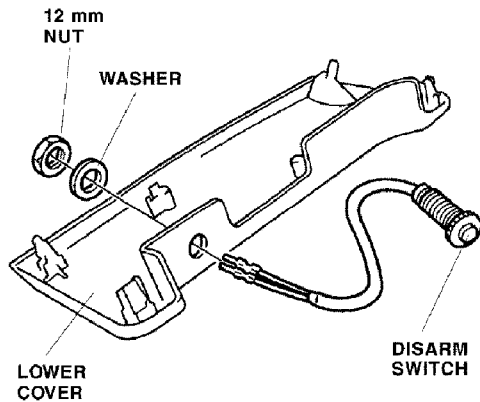

11. Locate the 3-pin connector included in the kit. Firmly push the disarm switch terminals into the 3-pin connector, and lower the lock. Make sure the terminals are positioned properly.

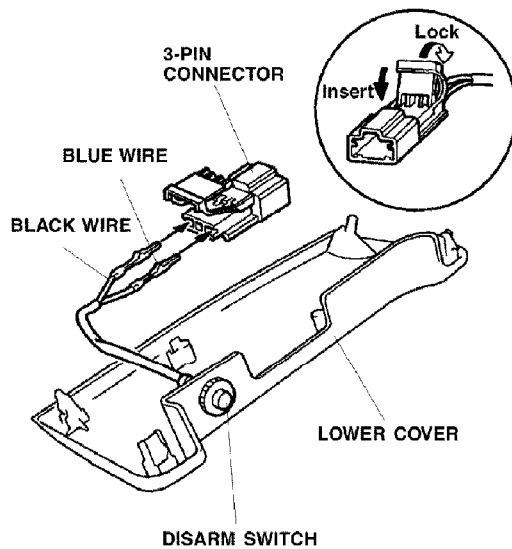

12. Position the 4-pin relay on the lower cover, and secure it with one self-tapping screw. Note the relay location.

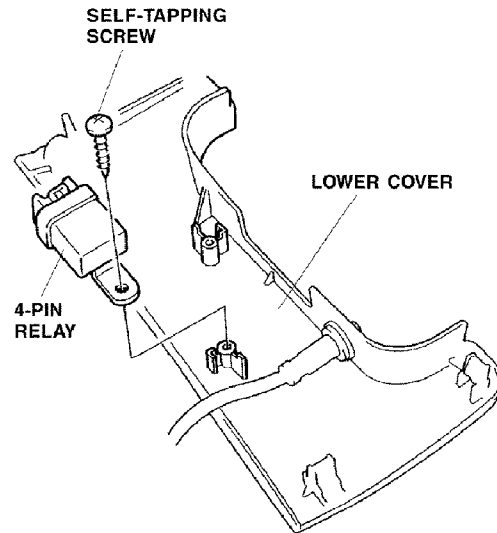

13. Measure and mark the upper steering column cover removed in step 4, and lightly center-punch the mark.

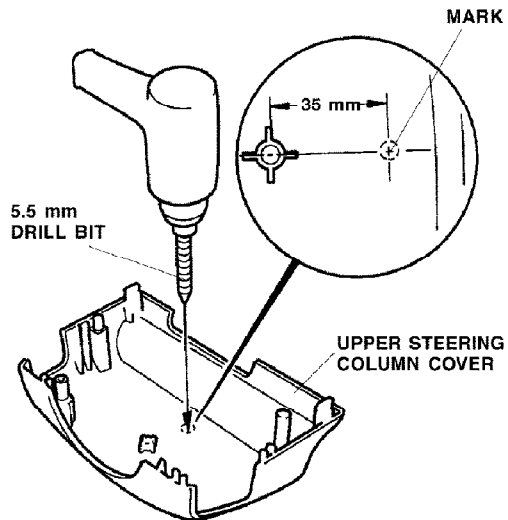

14. While wearing eye protection, drill a 5.5 mm hole through the center-punched mark. Remove all burrs.

15. Route the terminal ends of the LED through the hole just drilled, and secure the LED with the push nut. Install the push nut securely.

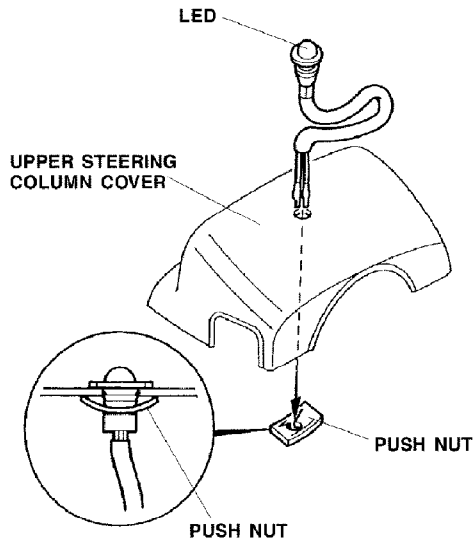

16. Position the control unit bracket on the control unit, and install the two 4 x 30 mm washer-screws.

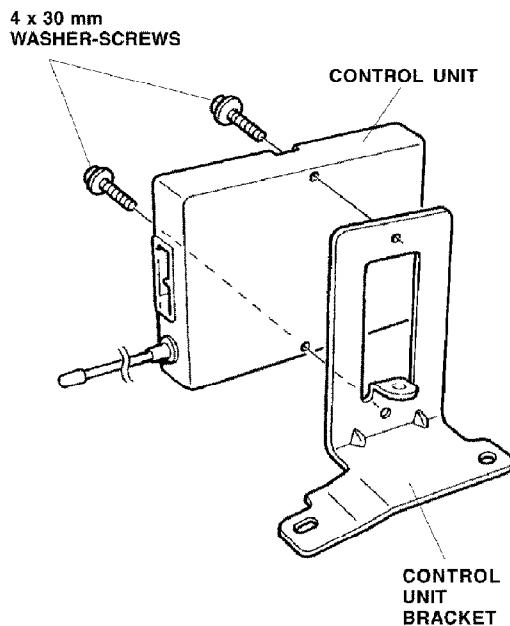

17. Above the accelerator pedal, locate the two studs and remove the nuts from the studs. Slide a collar onto each stud and reinstall the nuts. Position the control unit on the studs, and install the two 12 mm nuts supplied. Tighten the nuts securely.

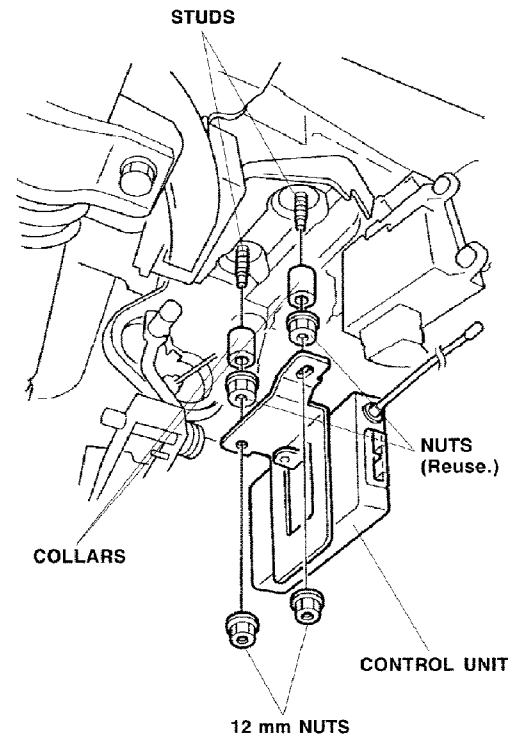

18. Secure the antenna of the control unit to the steering beam with one cushion tape in the area shown.

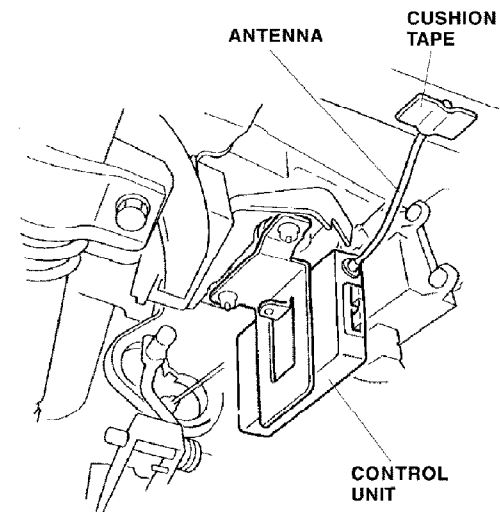

19. Remove the switch case.
- Using flat-tip screwdriver wrapped with a shop towel, gently pry out the switch case.
 - Mark the location of each connector.
 - Unplug the three connectors from the switch case, and pull out the switch case.

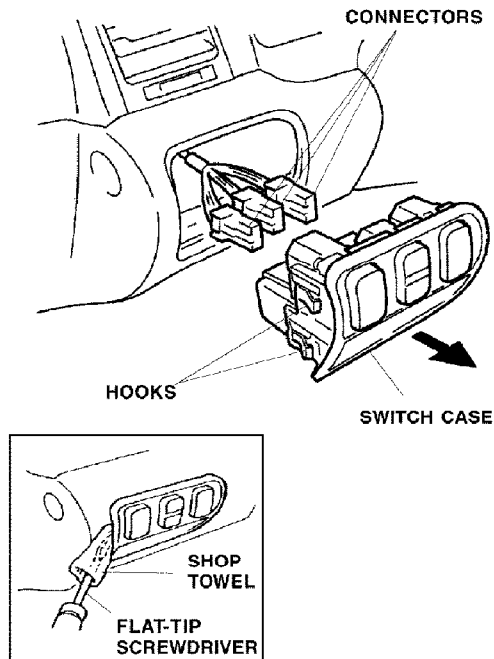

20. Unplug the 16-pin (blue) connector of the vehicle harness plugged into the top of the fuse box, and plug the 16-pin (blue) connector the security system harness in between.

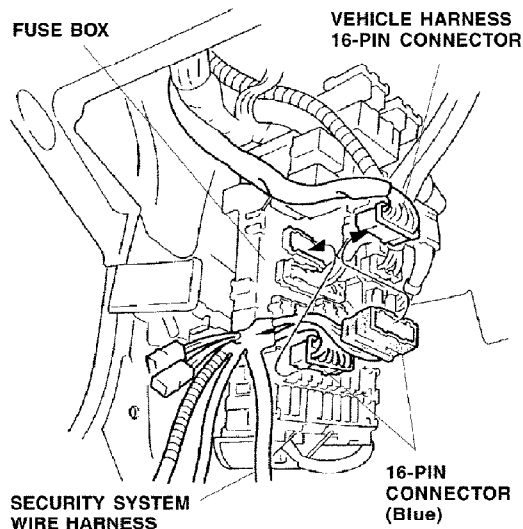

21. In the upper corner of the fuse box, locate the 2-pin and 3-pin connectors blue-taped to the vehicle harness. Remove the tapes to free the connectors. You may find the 3-pin connector near the terminals blue-taped to the vehicle harness or behind the vehicle harness.

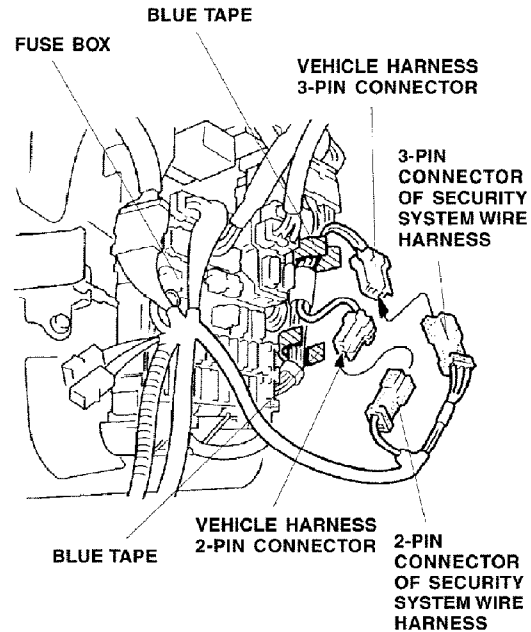

22. Plug the 2-pin and 3-pin connectors of the security system wire harness into the 2-pin and 3-pin connectors of the vehicle harness you just freed.

23. Unplug the 16-pin (gray) connector from the inside of the switch case, and plug the 16-pin (gray) connectors of the security system wire harness in between.

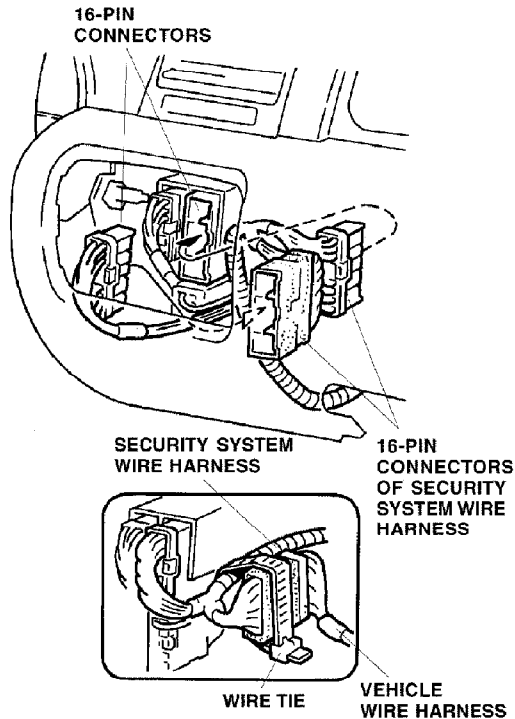

24. Secure the 16-pin connector of the vehicle harness to the security system wire harness with one wire tie.
25. Locate the 4-pin, 5-pin, and 6-pin connectors above the fuse box, and unplug the three connectors. Plug the 4-pin, 5-pin, and 6-pin connectors of the security system harness in between.

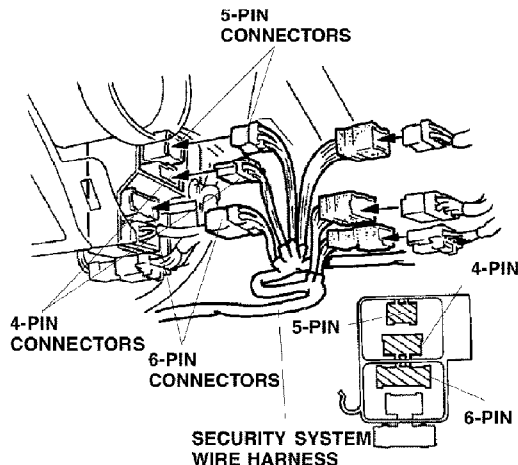

26. Plug the 22-pin connector of the security system wire harness into the control unit, then secure the harness to the vehicle harness with one wire tie in the area shown.

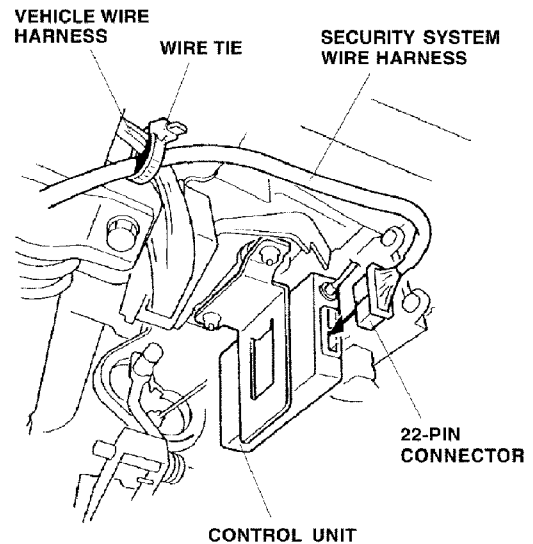

27. Route the LED harness installed in step 15 along the combination switch harness and secure it with one wire tie in the area shown. Reinstall the upper steering column cover.

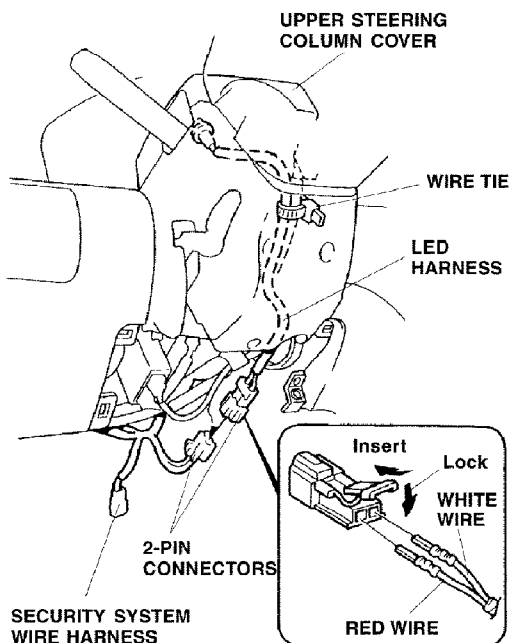

28. Locate the 2-pin connector included in the kit, and firmly push the LED terminals into the connector until they click into position, and lower the lock. Pull gently on the wires to verify that they are locked into the connector. Make sure that the terminals are positioned properly.
29. Plug the 2-pin connector of the LED harness into the 2-pin connector of the security system wire harness.

30. Connect the two fuse cases to each other, then connect them to the 16-pin connector of the security system wire harness. Attach the proper fuse label to each connector.

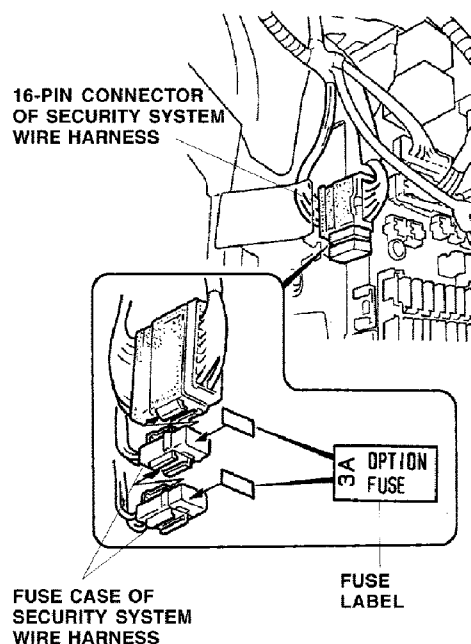

31. Attach the cushion tape to the fuse cases, then secure the harness with one wire tie. Make sure the cushion tape does not interfere with the fuse case covers.

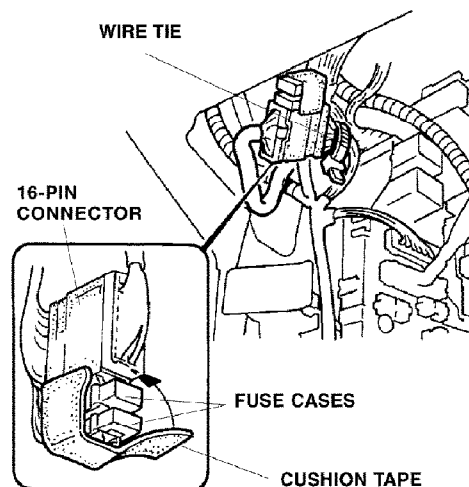

32. Route the security system wire harness under the fuse box, and secure it to the vehicle harness with the three wire ties in the areas shown.

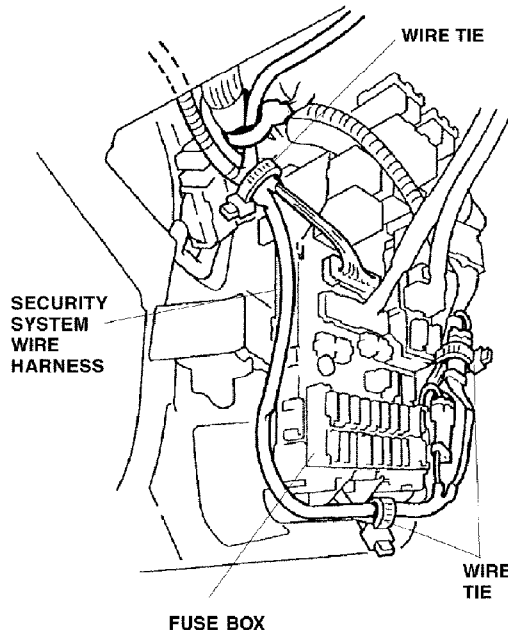

33. Under the steering column, secure the security system harness to the vehicle harness with the three wire ties. Open the fuse case cover, and attach the fuse labels (15 A) to the proper fuse case.

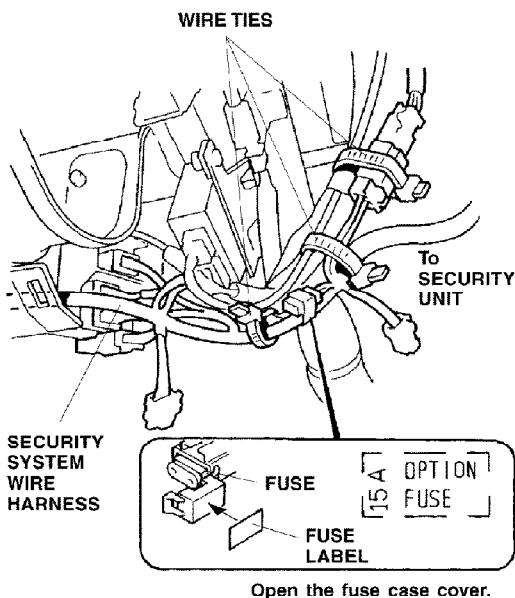

34. Plug the 4-pin connector of the security system wire harness into the 4-pin relay. Plug the 3-pin connector of the security system wire harness into the 3-pin connector from the disarm switch. Secure the 3-pin connectors to the harness with one wire tie. Reinstall the lower cover.

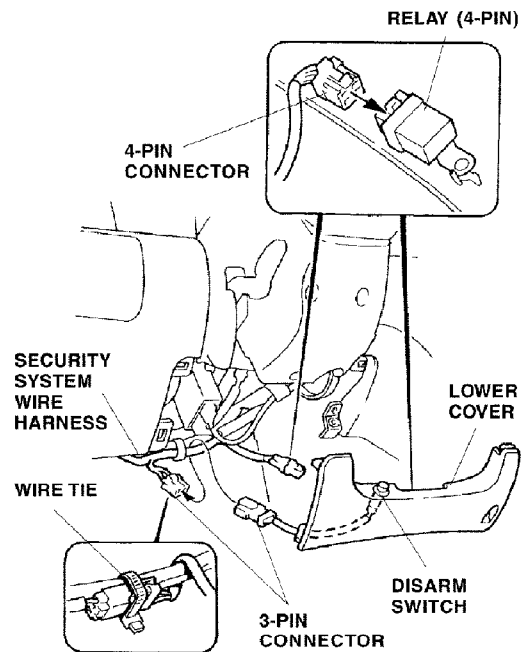

35. Check that all the wire harnesses and cables are routed properly and all the connectors are plugged in.
36. Reinstall all the removed parts.
37. Reconnect the negative cable to the battery.
38. Enter the customer's radio anti-theft code, if applicable, and reset the radio station presets.
39. Reset the clock.
40. Open the Owner's Manual (supplied) to page 11, and attach the seal to the bottom of the page as shown.

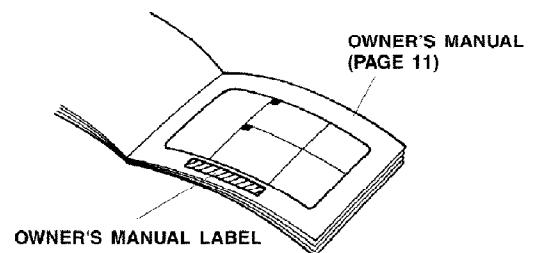

41. Check operation of the security system according to the Owner's Manual supplied.